

ECU[®]

Lamp Module Manual

ECU is a registered trademark of Engineering Concepts Unlimited Inc.

Copyright 2015 Engineering Concepts Unlimited Inc.

Contents

Unit review

LTO2 example

Unit Review

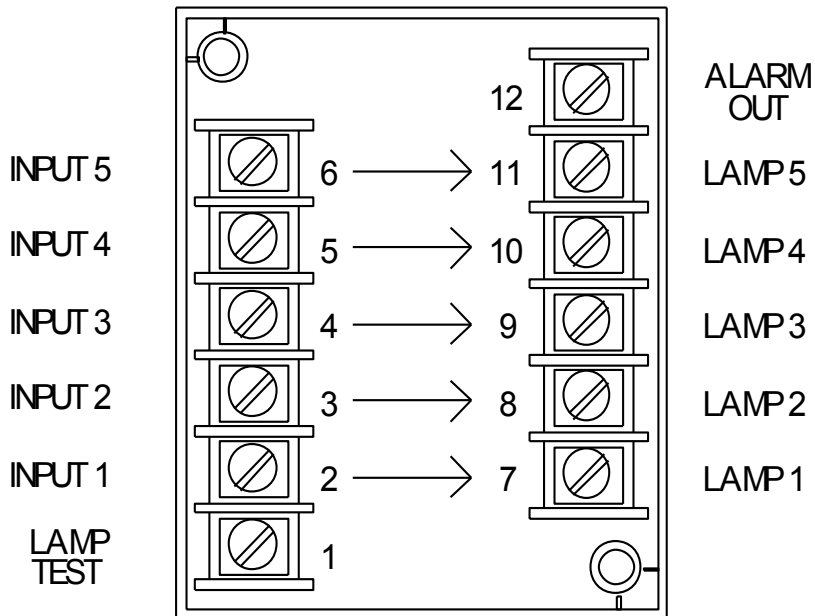

Lamp Module Terminal Drawing

The LTO2 AND LTO4 are highly flexible design components. It was originally developed for annunciation. It is still used for this and also for system fault isolation and lamp control. The LTO2 is shown for example but the LTO4 is identical in operation except for having for more lamp circuits.

Any voltage applied to the input terminals is output to the lamp terminal. It is also output to the Alarm out terminal. Thus all the inputs are “ORed” together through the Alarm out terminal. This product can be used to combine various signals into one output.

Lamp test applies power to all the output terminals at one time. It is a natural use for lamps but could also distribute a signal to many controls to do a joint shutdown. The unit can operate over the standard 9 to 30 Volts DC as long as the 1 amp maximum is observed.

Lamp Module Example

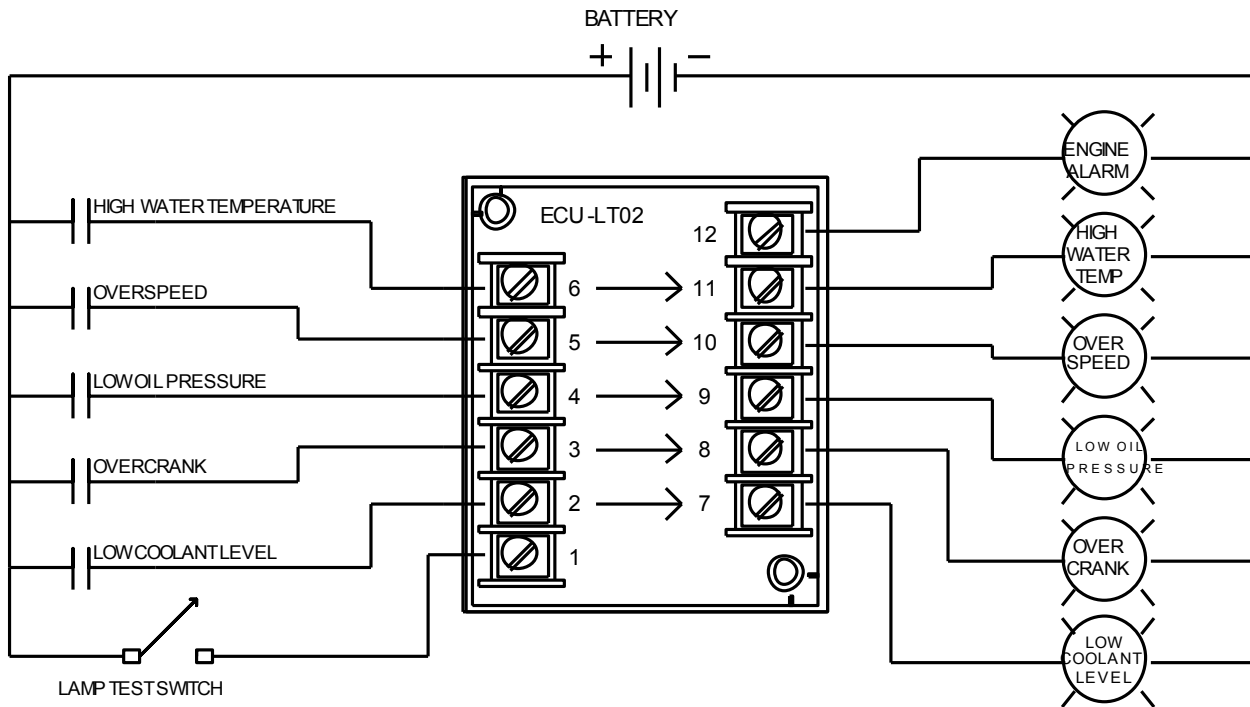

Basic Lamp Module operation

This is the classic use of the Lamp Module. It is shown handling many inputs and operating the corresponding lamps. The Lamp test switch is used to feed the commons voltage to all the lamps. It should be noted that all circuits contain anti-backfeed diodes thus precluding lamp test voltage from infiltrating the input voltages terminals.

The only difference between the LTO2 and LTO4 is the circuit count and the fact the LTO2 is in an ABS plastic case and the LTO4 is in a heavy duty Zinc Cast Box.

If you need simple diodes in a package see the DAO1 module.