

ENGINE SYSTEM CONTROLLER WITH INTEGRATED LOAD BANK CONTROL

The ECU-835 engine system controller provides reconfigurable control and diagnostic functions for today's advanced, CANBUS enabled engine systems. Additionally, the ECU-835 provides automated load bank control, telematics integration, and three special function relay outputs.

ECU[®] - 835

**ONE VERSION FOR
12 AND 24 VDC**

APPLICATIONS: CANBUS Engine Systems with Load Banks

FEATURES:

- Laptop-free configuration, diagnostics, and firmware update in the field
- Zero power consumption when off
- Hour Check input for one-touch hourmeter, battery voltage, and fuel level check
- Tactile feedback membrane switches
- Rugged and reliable
- Epoxy encapsulated
- Compatible with ECU-GAUGE integrated gauge panel for economical, user-friendly indication
- Integrated load bank control
- RS-232 and RS-485 communication interfaces



INTEGRATED CONTROL AND DIAGNOSTICS

The ECU-835 includes engine specific software that tailors the ECU-835 to the specific engine system, including a fault code database that contains SPN.FMI, PGN, and internally sourced status, maintenance, pre-alarm, and shutdown messages. This database enables live, post-shutdown, and DM2 examination of active messages in natural language without the need for a fault code book, skilled technician, or special equipment.

The appearance of new pre-alarm messages or a shutdown message is annunciated both on the front panel of the ECU-835, and via the closure of the acknowledgeable alarm contact. Active messages can be viewed in the "Message Center" display on the home screen, as well as in a scrollable format in the "DM1 + Active Messages" utility. The decoded DM2 record from the ECM can be viewed via the "DM2" utility. For post-shutdown diagnostic purposes, the "Last Shutdown" utility provides a hourmeter time stamped log of messages active when the last shutdown occurred.

The RS-485 Modbus master connection enables robust communication with other devices, including the ECU-GAUGE panel, which displays essential data in a familiar mechanical gauge format. An RS-232 communications connection is also provided to enable direct communication with a telematics device or modem.

To address thermal performance concerns especially prevalent in diesel engines under light loads or operating in extremely cold climates, an automatic load bank control system has been integrated into the ECU-835. By using available data and with ECU, Inc. control software, multi-modal load bank control is achieved with no end-user interaction needed. A password protected on-board diagnostic utility for the load bank control is provided for service technicians.

**ECU[®] IS A REGISTERED TRADEMARK OF
ENGINEERING CONCEPTS UNLIMITED, INC.**

P.O. BOX 250 - 8950 TECHNOLOGY DRIVE - FISHERS, IN 46038
Voice: 317-849-8470 Fax: 317-849-6475 E-Mail: sales@ecu-engine-controls.com

**SAMPLE ECU®-835 APPLICATION:
EXTERNAL SWITCH TYPE PANEL CONFIGURATION**

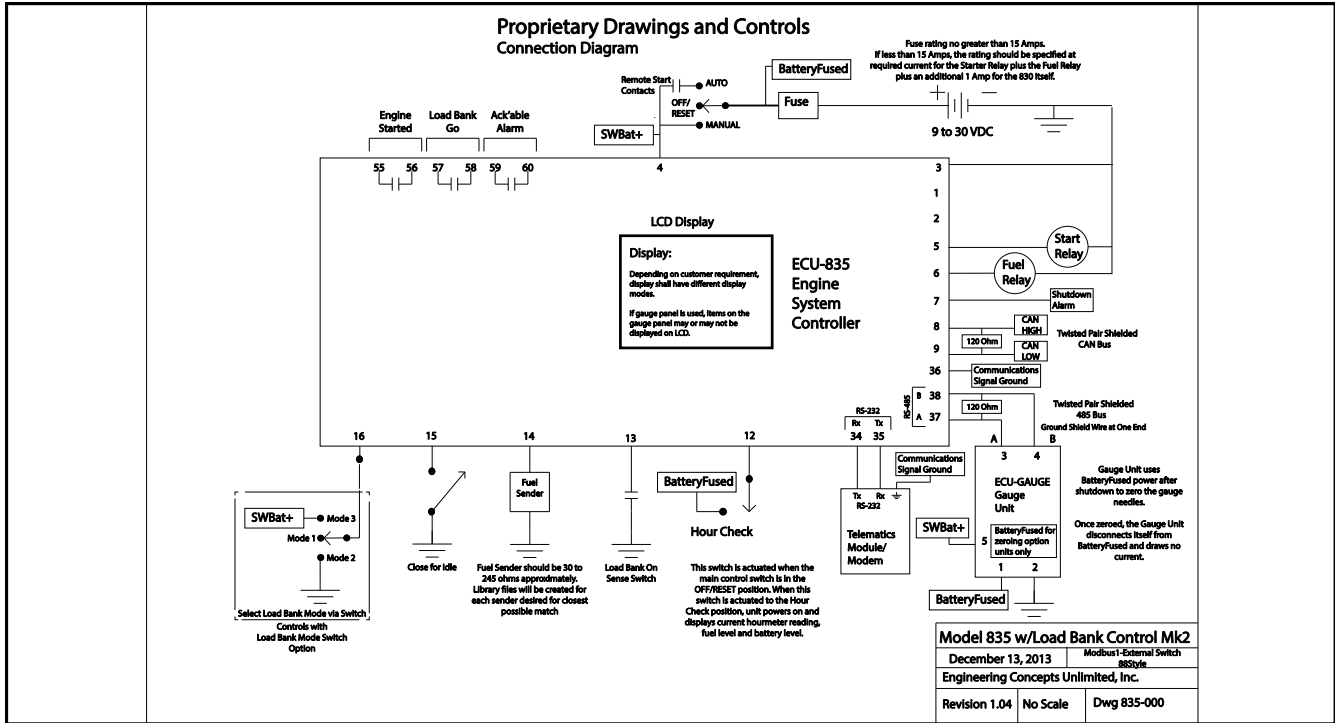

The above example shows the ECU-835 configured for standard operation. An ECU-GAUGE unit is shown connected to provide electro-mechanical gauge display of data collected by the ECU-835. Upon power off, the attached ECU-GAUGE unit moves its gauges to their zero positions then disconnects itself from battery power, resulting in a zero power standby.

Depending on final configuration some options, such as 50/60Hz selection, may be password protected.

SPECIFICATIONS:

INPUT VOLTAGE:	9 TO 30	V _{DC}
OUTPUT RATING:	5	A MAX
OPERATIONAL TEMPERATURE:	-40 TO 85	°C (OPERATIONAL)
LCD (w/HEATER OPTION):	-40 TO 75	°C

ECU® -835 TERMINAL OUT

Please see the above application for terminal output specification.

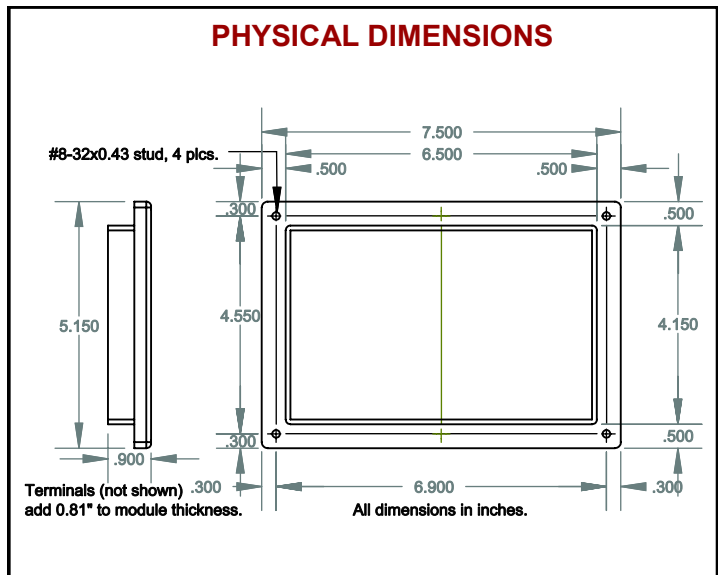

ORDERING INFORMATION:
ORDER BY SPECIFYING: ECU®-835

**ECU® IS A REGISTERED TRADEMARK OF
ENGINEERING CONCEPTS UNLIMITED, INC.**